

Vandal-Resistant Fixtures

The vandal-resistant fixtures shown here are representative of the many styles available. Please refer to a WaterSaver Vandal-Resistant Service

Fixture brochure or a WaterSaver engineering catalog for complete information.

Application: Vandal-resistant deck mounted turret base with single ground key cock valve. Valve provides on/off control of gas, air and vacuum services only. Lever handle provides visual indication of valve position.

Vandal-resistant features:

- Inlet shank is 3/8" IPS heavy wall pipe to resist breakage.
- Turret base has pins to prevent turning fixture on counter.
- Valve has internal check valve to prevent backflow into gas system.

- Recessed gas cock nut has nonremovable pin to prevent disassembly.
- Index disc is cemented in place.
- All threaded connections are secured with cement.

ADDITIONAL MODELS

VR2900-132AWSA Same as above except with two valves at 90 degrees.

VR2900-132SWSA Same as above except with two valves at 180 degrees.

VR2900-131WSA

*Ground Key Cock Assembly,
Vandal-Resistant*

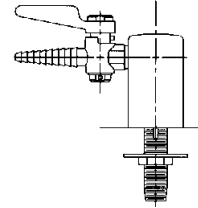

Application: Vandal-resistant deck mounted single faucet with 6" rigid vacuum breaker gooseneck and serrated hose end. Furnished with WaterSaver self-contained renewable unit with stainless steel valve seat.

Vandal-resistant features:

- Faucet base has pins to prevent turning fixture on counter.
- Packing nut is secured with set screw to prevent removal.
- Index disc is cemented in place.

- Gooseneck riser is 1/2" IPS heavy wall pipe to resist bending and breakage.
- Vacuum breaker cover has vandal-resistant screws to prevent removal.
- Round serrated hose end is cemented in place to prevent removal.
- All threaded connections are secured with cement.

ADDITIONAL MODEL

VR411VB Same as above except mixing faucet for hot and cold water.

VR611VB

*Deck Mounted Single Faucet,
Vandal-Resistant*

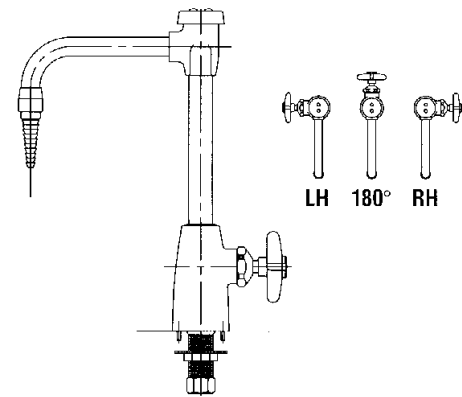

Application: Vandal-resistant double service fixture for cold water and gas. All-forged brass construction for superior strength and durability. Furnished with WaterSaver self-contained renewable unit with stainless steel valve seat. Two ground key cock valves for gas service.

Vandal-resistant features:

- Dual inlet shanks prevent turning fixture on counter.
- Inlet shanks are 3/8" IPS heavy wall pipe to resist breakage.
- Ground key cocks have internal check valves to prevent backflow into gas system.
- Recessed gas cock nuts have

- nonremovable pin to prevent disassembly.
- Index discs are cemented in place.
- Fixture riser is 1/2" IPS heavy wall pipe to resist bending and breakage.
- Hooded nylon handle conceals water valve stem and packing nut. Nut has set screw to prevent removal.
- Round serrated hose end is cemented in place.
- All threaded connections are secured with cement.

ADDITIONAL MODEL

VR5310WSA Same as above except with in-line vacuum breaker on water outlet.

VR5300WSA

*Combination Gas/Cold
Water Fixture,
Vandal-Resistant*

